

Introduction

The following sports data sheets are for use in conjunction with Sport England's 'Developing the Right Sports Hall' (DRSH) main document. They relate to Step 5 'Establishing the Project Brief' and identify the needs of the priority sport and the key secondary sports.

These sheets show the requirements for Badminton as the 'Priority Sport' at various levels of play and other 'Secondary Sports' that can fit into the same overall space. Layouts for 1, 2, 3, 4 and 5 courts have been included.

New Level of Play Category ¹	Level of Play			
	International	Premier	Club	Community
	This category relates to the lowest level of International play ²	This category relates a Premier / National League Club competing in regional or Inter county competitions	This category relates to a local club competing in District and County League competitions	This category relates to school and community use where there is no formal competitive structure / no specific need for space for officials or spectator accommodation
Badminton equivalent ³	International High Performance Centres	Inter-County Championships BADMINTON England Tournament Circuits Premier Club in a Performance Centre	Premier Club in a Community Badminton Network	Recreational Club

Commentary

The sports data sheets use the NGB's requirements for the field of play. The additional space requirements for officials are indicated separately as 'optional'. Spectators zones for match play are not included and are assumed to be a site specific requirement. For further details of the requirements for badminton see the Badminton England (BE) website: <http://www.badmintonengland.co.uk> and the Sport England design guidance note 'Badminton'. For further details of the requirements for 'secondary sports', see Appendix 8 of the main DRSH document for links to other NGB's websites.

¹ New level of play categories for each sport as agreed by the NGBs and Sport England and applicable throughout this document.

² For higher levels of international competition, such as major championships, the relevant NGB should be consulted at a very early stage as the requirements vary considerably.

³ For other sports, see Appendix 4 'Level of play categories for each sport' within main document



Key Issues

- **Space above court:** No obstructions within a clear height zone above the principal playing area and extending 0.75 m beyond the side lines and 2.0 m beyond the back lines.
- **Flooring:** Vinyl point elastic over an area elastic base is the preferred playing surface (i.e. a combined-elastic floor). For alternative surfaces and performance criteria, see Table 4 of Sport England's design guidance note on 'Badminton'. Floor sockets to be flush with the floor surface.
- **Walls / division curtains / blinds:** Backgrounds to be a constant colour and have a light reflectance value (LRV) between 30 - 50%.
- **Acoustics:** Reverberation time to be 1.5 - 2.0 seconds at mid frequency.
- **Lighting:** No luminaires permitted above the court and a 2.0 m zone at the back of the court. Luminaires to be positioned centrally above the run offs between the courts. Any luminaires in the line of sight of players to be switched off. Windows to be screened off to avoid sun penetration and glare.
- **Heating and ventilation:** Temperature range 12 - 20°C (16°C preferred). Air velocities < 0.1 m/s or systems capable of being temporarily switched off by players.

Note: For further details see Sport England's design guidance notes 'Badminton', 'Floors for Indoor Sports' and 'Artificial Sports Lighting'.

Primary Sport

Badminton - Overview		Source of information:		http://www.badmintonengland.co.uk http://www.sportengland.org/facilities_planning/design_and_cost_guidance.aspx											
International	Premier	Overall space (m) incl. R/O													
		Principal playing area (m)			Run offs (m)			Additional areas (m)		Specification					
		L x	W x	H	Ends	Sides	Between courts / Between courts with a dividing net	T/O	SS	Flooring	Lighting				
		International	17.40	10.10	9.00	13.40	6.10	9.00	2.00	2.00	Sides: 2.00/3.00 Ends: - /4.00	Essential	Essential	Combined elastics	1000 lux 0.7 Emin / eav
		Premier	17.40	9.10	9.00	13.40	6.10	9.00	2.00	1.50	1.50/2.60 Ends: - /4.00	Optional	Optional	Combined, area or mixed elastics	500 lux 0.7 Emin / eav
		Club	17.40	9.10	7.50	13.40	6.10	7.50	2.00	1.50	Sides: 1.50/2.60 Ends: - /3.00	Optional	Optional	Combined, area or mixed elastics	500 lux 0.7 Emin / eav
		Community	17.40	9.10	6.70	13.40	6.10	6.70	2.00	1.50	1.50/2.40 Ends: - /3.00	Optional	Optional	Combined, area or mixed elastics	500 lux 0.7 Emin / eav

Primary Sport

Badminton - 1 Court				Source of information:		http://www.badmintonengland.co.uk http://www.sportengland.org/facilities_planning/design_and_cost_guidance.aspx									
Community				Overall space (m) incl. R/O 17.40 x 9.10 x 6.70											
				Principal playing area (m)			Run offs (m)			Additional areas (m)		Specification			
				L x			R/O			T/O	S/S				
				W x	Length	Width	Height	Ends	Sides	Between courts / Between courts with a dividing net	Space for teams (T) and match officials (O)	Spectator seating	Flooring	Lighting	
				H											
				17.40	13.40	6.10	6.70	2.00	1.50	1.50/ N/A	N/A	N/A	Combined, area or mixed elastics	500 lux 0.7 Emin / eav	
Secondary Sports															
Sport	Number	Compliance	Level												
Basketball	0 court format	✗	-	32.10 19.10 7.00	28.00	15.00	7.00	2.05	2.05	-	-	-	Semi-sprung wooden or synthetic	Same (500 lux)	
Indoor Cricket	0 lanes	✗	-	33.62 12.72 7.70	31.62	3.66	7.70	1.00	1.00	3.40 for basket - ball goal	-	-	Mats req/d (to ECB standards)	Higher (750 lux)	
Volleyball	0 court format (lengthways)	✗	-	24.00 15.00 7.50	18.00	9.00	7.50	3.00	3.00	6.00 / 6.00	-	-	Area elastic	Same (500 lux)	
Volleyball Training	0 court format (transverse)	✗	-	20.00 15.00 7.50	18.00	9.00	7.50	1.00	3.00	6.00 / 6.00	-	-	Area elastic	Same (500 lux)	
Basketball Training	Rings on side walls	✓	Training	- - -											

Primary Sport / Secondary Sport Issues

Badminton - 1 Court (cont/d)

Notes of key issues for community level badminton

- See 'Key Issues' on page 1 cover sheet

Secondary Sports

Layouts for other sports within a community badminton space of 17.40 x 9.10 x 6.7 m

Netball

Basketball

Indoor Cricket

Volleyball

**Volleyball Training
(transverse)**

**Basketball
Training**

- cannot be
accommodated in a single
court badminton space

- can be
accommodated in a
single court
badminton space

- number and location
to project specific
requirements

Primary Sport

Badminton - 2 Court				Source of information:		http://www.badmintonengland.co.uk http://www.sportengland.org/facilities_planning/design_and_cost_guidance.aspx									
Community / Club				Overall space (m) incl. R/O 17.40 x 16.70 x 6.70 / 7.50											
				Principal playing area (m)			Run offs (m)			Additional areas (m)		Specification			
				R/O			T/O		S/S	Specification					
				L x W x H	Length	Width	Height	Ends	Sides	Between courts/ Between courts with a dividing net	Space for teams (T) and match officials (O)	spectator seating	Flooring	Lighting	
				17.40 16.70 6.70/7.50	13.40	6.10	6.70 7.50	2.00	1.50	1.50/2.40 1.50/2.60	Optional	Optional	Combined, area or mixed elastics	500 lux 0.7 Emin / eav	
Secondary Sports															
Sport	Number	Compliance	Level												
Basketball	0 court format	✗	-	32.10 19.10 7.00	28.00	15.00	7.00	2.05	2.05	-	-	-	Semi-sprung wooden or synthetic	Same (500 lux)	
Indoor Cricket	0 lanes	✗	-	33.62 12.72 7.70	31.62	3.66	7.70	1.00	1.00	3.40 for basket - ball goal	-	-	Mats req/d (to ECB standards)	Higher (750 lux)	
Volleyball	0 court format (lengthways)	✗	-	24.00 15.00 7.50	18.00	9.00	7.50	3.00	3.00	6.00 / 6.00	-	-	Area elastic	Same (500 lux)	
Volleyball Training	0 court format (transverse)	✗	-	20.00 15.00 7.50	18.00	9.00	7.50	1.00	3.00	6.00 / 6.00	-	-	Area elastic	Same (500 lux)	
Basketball Training	Rings on side walls	✓	Training	- - -											

Primary Sport / Secondary Sport Issues

Badminton - 2 Court (cont/d)

Notes of key issues for a two court community / club level badminton space

- See 'Key Issues' on page 1 cover sheet

Secondary Sports

Layouts for other sports within a two court badminton space of 17.40 x 16.70 x 6.70 / 7.50 m

Netball

Basketball

Indoor Cricket

Volleyball

**Volleyball Training
(transverse)**

**Basketball
Training**

- cannot be
accommodated in a two
court badminton space

- can be
accommodated in a
two court badminton
space

- number and location
to project specific
requirements

Primary Sport

Badminton - 3 Court				Source of information:		http://www.badmintonengland.co.uk http://www.sportengland.org/facilities_planning/design_and_cost_guidance.aspx											
Community / Club				Overall space (m) incl. R/O 24.30 x 17.40 x 6.70 / 7.50													
				Principal playing area (m)			Run offs (m)			Additional areas (m)		Specification					
							R/O			T/O	S/S						
				L x W x H	Length	Width	Height	Ends	Sides	Between courts / Between courts with a dividing net	Space for teams (T) and match officials (O)	Spectator seating	Flooring	Lighting			
				24.30	13.40	6.10	6.70 / 7.50	2.00	1.50	1.50/2.40 / 1.50/2.60	Optional	Optional	Combined, area or mixed elastics	500 lux / 0.7 Emin / eav			
Secondary Sports																	
Sport	Number	Compliance	Level														
Basketball	0 court format	✗	-	32.10 19.10 7.00	28.00	15.00	7.00	2.05	2.05	-	-	-	Semi-sprung wooden or synthetic	Same (500 lux)			
Indoor Cricket	0 lanes	✗	-	33.62 12.72 7.70	31.62	3.66	7.70	1.00	1.00	3.40 for basket - ball goal	-	-	Mats req/d (to ECB standards)	Higher (750 lux)			
Volleyball	1 court format (lengthways)	✓	Community / Club	24.0/24.0 15.0/17.0 7.50/7.50	18.00	9.00	7.50	3.00	3.00	6.00 / 6.00	2.00 (Club)	-	Area elastic	Same (500 lux)			
Volleyball Training	0 court format (transverse)	✗	-	20.00 15.00 7.50	18.00	9.00	7.50	1.00	3.00	6.00 / 6.00	-	-	Area elastic	Same (500 lux)			
Basketball Training	Rings on side walls	✓	Training	- - -													

Primary Sport / Secondary Sport Issues

Badminton - 3 Court (cont/d)

Notes of key issues for a three court community / club level badminton space

- See 'Key Issues' on page 1 cover sheet.
- Hatched areas indicate space which is in excess to secondary sport requirements. In some cases, this can provide improved circulation and space for spectators and wheelchair users.
- Community level badminton height of 6.7 m can accommodate volleyball at community level (see below) but with restricted headroom (below 7.5 m required) subject to agreement / conditions of use.

Secondary Sports

Layouts for other sports within a three court badminton space of 24.30 x 17.40 x 6.70 / 7.50 m

Netball

- cannot be accommodated in a three court badminton space

Basketball

Indoor Cricket

Volleyball (Community) with restricted headroom subject to agreement

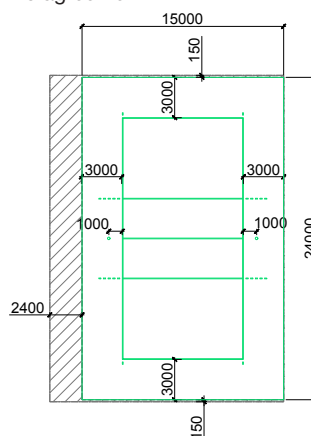

Volleyball (Club)

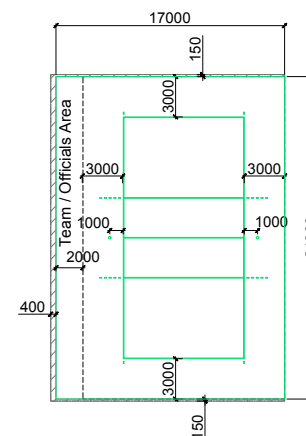

Volleyball Training (transverse)

- cannot be accommodated in a three court badminton space unless it is made wider and longer

Basketball Training

- can be accommodated in a three court badminton space
- number and location to project specific requirements

Primary Sport

Badminton - 4 Court				Source of information:		http://www.badmintonengland.co.uk http://www.sportengland.org/facilities_planning/design_and_cost_guidance.aspx											
Community / Club / Premier				Overall space (m) incl. R/O 31.90 x 17.40 x 6.70 / 7.50 / 9.00													
				Principal playing area (m)			Run offs (m)			Additional areas (m)		Specification					
							R/O			T/O	S/S						
				L x W x H	Length	Width	Height	Ends	Sides	Between courts / Between courts with a dividing net	Space for teams (T) and match officials (O)	Spectator seating	Flooring	Lighting			
				31.90 17.40 6.7/7.5/9.0	13.40	6.10	6.70 7.50 9.00	2.00	1.50	1.50/2.40 1.50/2.60	Optional	Optional	Combined, area or mixed elastics	500 lux 0.7 Emin / eav			
Secondary Sports																	
Sport	Number	Compliance	Level														
Netball	0 court format	✗	-	34.50 18.25 7.50	30.50	15.25	7.50	2.00	1.50	3.00 / 3.00	-	-	Any meeting AENA standards	Higher (750 lux)			
Basketball	0 court format	✗	-	32.10 19.10 7.00	28.00	15.00	7.00	2.05	2.05	-	-	-	Semi-sprung wooden or synthetic	Same (500 lux)			
Indoor Cricket	0 lanes (However, 2 lanes could be agreed with ECB - see note overleaf)	✗	Community / Club	33.62 12.72 7.70	31.62	3.66	7.70	1.00	1.00	3.40 for basket - ball goal	-	-	Mats req/d (to ECB standards)	Higher (750 lux)			
Volleyball	1 court format (lengthways)	✓	Community / Premier	24.0/28.0 15.0/17.0 7.50/7.50	18.00	9.00	7.50	3.00 / 5.00	3.00	6.00 / 6.00	2.00 (Premier)	-	Area elastic	Same (500 lux)			
Volleyball Training	0 court format (transverse)	✗	-	20.00 15.00 7.50	18.00	9.00	7.50	1.00	3.00	6.00 / 6.00	-	-	Area elastic	Same (500 lux)			
Basketball Training	Rings on side walls	✓	Training	- - -													

Primary Sport / Secondary Sport Issues

Badminton - 4 Court (cont/d)

Notes of key issues for a four court badminton space

- See 'Key Issues' on page 1 cover sheet
- Hatched areas indicate space which is in excess to secondary sport requirements. In some cases, this can provide improved circulation and space for spectators and wheelchair users.
- The space cannot accommodate a full size 28.0 x 15.0 m basketball court and run off's. However, the rules can allow reduced court and run off sizes - see England Basketball rules.
- Community level badminton height of 6.7 m can accommodate Volleyball at community level (see below) but with restricted headroom (below 7.5 m required) subject to agreement / conditions of use.
- Indoor cricket: A reduced runup length (as indicated below) could be agreed with the ECB on a project by project basis (see ECB TS3 guidance note). However, lighting requirements for indoor cricket exceed those of badminton at community, club and premier levels of play, as indicated. Court space around the nets is also an important consideration. For instance, 2 lanes with adequate space around for additional safe practice / padding up can be preferable to 4 lanes with insufficient space for safe padding up and other practice.
- The minimum safety margins indicated between the cricket practice nets and walls should be increased if basketball training rings are fitted to the side walls - see the ECB TS3 document for further advice on recommended clearances.

Secondary Sports

Layouts for other sports within a four court badminton space of 31.90 x 17.40 x 6.70 / 7.50 / 9.00 m

Netball

- cannot be accommodated in a four court badminton space, unless it is made wider and longer

Basketball

- see note above

Indoor Cricket (see note above)

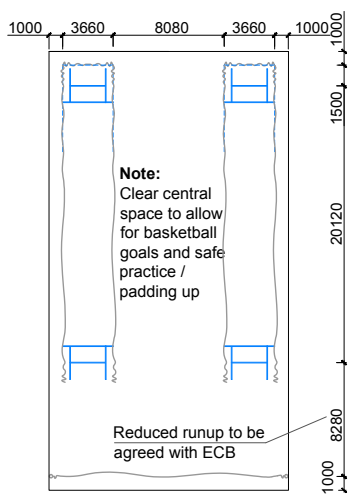

Volleyball (Community)

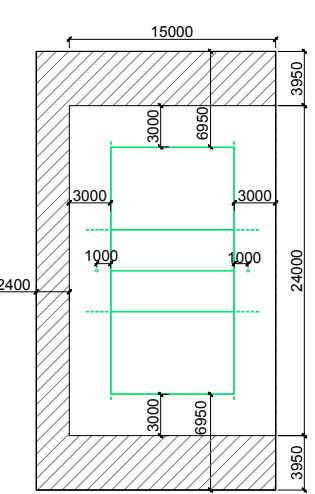

Volleyball (Premier)

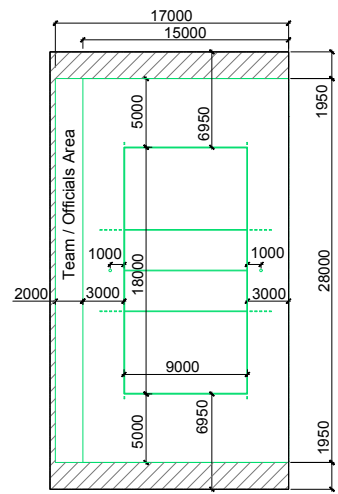

Volleyball Training (transverse)

- cannot be accommodated in a four court badminton space, unless it is made wider

Basketball Training

- can be accommodated in a four court badminton space
- number and location to project specific requirements

Primary Sport

Badminton - 4 Court (Int)				Source of information:		http://www.badmintonengland.co.uk http://www.sportengland.org/facilities_planning/design_and_cost_guidance.aspx											
International				Overall space (m) incl. R/O 34.40 x 17.40 x 9.00													
				Principal playing area (m)			Run offs (m)			Additional areas (m)		Specification					
							R/O			T/O S/S							
				L x W x H	Length	Width	Height	Ends	Sides	Between courts / Between courts with a dividing net	Space for teams (T) and match officials (O)	Spectator seating	Flooring	Lighting			
				34.40	17.40	9.00	13.40	6.10	9.00	2.00	2.00	2.00/3.00	Essential	Essential	Combined elastics	1000 lux 0.7 Emin / eav	
Secondary Sports																	
Sport	Number	Compliance	Level														
Netball	0 court format	✗	-	34.50 18.25 7.50	30.50	15.25	7.50	2.00	1.50	3.00 / 3.00	-	-	Any meeting AENA standards	Lower (750 lux)			
Basketball	0 court format	✗	-	32.10 19.10 7.00	28.00	15.00	7.00	2.05	2.05	-	-	-	Semi-sprung wooden or synthetic	Lower (500 lux)			
Indoor Cricket	2 lanes	✓	Community / Club	33.62 12.72 7.70	31.62	3.66	7.70	1.00	1.00	3.40 for basket - ball goal	-	-	Mats req/d (to ECB standards)	Lower (750 lux)			
Volleyball	1 court format (lengthways)	✓	Premier	28.00 17.00 7.50	18.00	9.00	7.50	5.00	3.00	6.00 / 6.00	2.00	-	Area elastic	Lower (500 lux)			
Volleyball Training	0 court format (transverse)	✗	-	20.00 15.00 7.50	18.00	9.00	7.50	1.00	3.00	6.00 / 6.00	N/A	N/A	Area elastic	Lower (500 lux)			
Basketball Training	Rings on side walls	✓	Training	- - -													

Primary Sport / Secondary Sport Issues

Badminton - 4 Court International (cont/d)

Notes of key issues for a four court international badminton space

- See 'Key Issues' on page 1 cover sheet.
- Hatched areas indicate space which is in excess to secondary sport requirements. In some cases, this can provide improved circulation and space for spectators and wheelchair users.
- For competition play, no allowance has been made for any officials beyond the end run off zones.
- The space cannot accommodate a full size 28.0 x 15.0 m basketball court and run off's. However, the rules can allow reduced court and run off sizes - see England Basketball rules.
- The 17.4 m width accommodates two indoor cricket lanes with a clear central zone for potential basketball goals. (See ECB TS3 document pages 6 and 7 for criteria). Court space around the nets is also an important consideration. For instance, 2 lanes with adequate space around for additional safe practice / padding up can be preferable to 4 lanes with insufficient space for safe padding up and other practice.
- The minimum safety margins indicated between the cricket practice nets and walls should be increased if basketball training rings are fitted to the side walls - see the ECB TS3 document for further advice on recommended clearances.

Secondary Sports

Layouts for other sports within a four court international badminton space of 34.40 x 17.40 x 9.00 m

Netball

- cannot be accommodated in a four court international badminton space, unless it is made wider and longer

Basketball

- see note above

Indoor Cricket

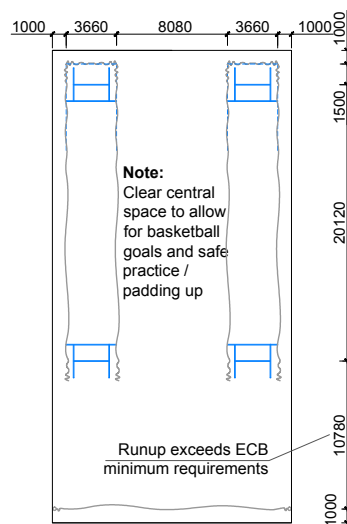

Volleyball (Premier)

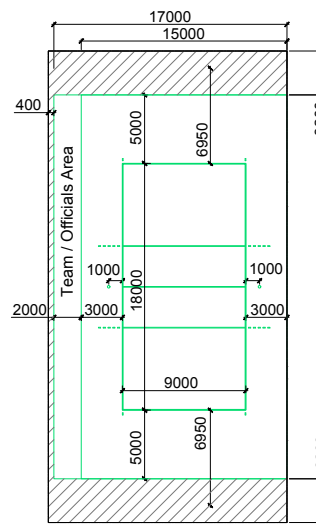

Volleyball Training (transverse)

- cannot be accommodated in a four court international badminton space, unless it is made wider

Basketball Training

- can be accommodated in a four court international badminton space
- number and location to project specific requirements

Primary Sport

Badminton - 5 Court				Source of information:		http://www.badmintonengland.co.uk http://www.sportengland.org/facilities_planning/design_and_cost_guidance.aspx																
Community / Club / Premier				Overall space (m) incl. R/O 39.50 x 17.40 x 6.70 / 7.50 / 9.00																		
				Principal playing area (m)			Run offs (m)			Additional areas (m)		Specification										
				Length	Width	Height	Ends	Sides	Between courts / Between courts with a dividing net	Space for teams (T) and match officials (O)	Spectator seating	Flooring	Lighting									
														T/O	S/S							
L x	W x	H																				
39.50	17.40	6.7/7.5/9.0		13.40	6.10	6.70 7.50 9.00	2.00	1.50	1.50/2.40 1.50/2.60	Optional	Optional	Combined, area or mixed elastics	500 lux 0.7 Emin / eav									
Secondary Sports																						
Sport	Number	Compliance	Level																			
Netball	0 court format	✗	-	34.50 18.25 7.50	30.50	15.25	7.50	2.00	1.50	3.00 / 3.00	-	-	Any meeting AENA standards	Higher (750 lux)								
Basketball	0 court format	✗	-	32.10 19.10 7.00	28.00	15.00	7.00	2.05	2.05	-	-	-	Semi-sprung wooden or synthetic	Same (500 lux)								
Indoor Cricket	2 lanes	✓	Community / Club	33.62 12.72 7.70	31.62	3.66	7.70	1.00	1.00	3.40 for basket - ball goal	-	-	Mats req/d (to ECB standards)	Higher (750 lux)								
Volleyball	1 court format (lengthways)	✓	Community / Premier	24.0/28.0 15.0/17.0 7.50/7.50	18.00	9.00	7.50	3.00 / 5.00	3.00	6.00 / 6.00	2.00 (Club)	-	Area elastic	Same (500 lux)								
Volleyball Training	0 court format (transverse)	✗	-	20.00 15.00 7.50	18.00	9.00	7.50	1.00	3.00	6.00 / 6.00	N/A	N/A	Area elastic	Same (500 lux)								
Basketball Training	Rings on side walls	✓	Training	- -																		

Primary Sport / Secondary Sport Issues

Badminton - 5 Court (cont/d)

Notes of key issues for a five court badminton space

- See 'Key Issues' on page 1 cover sheet
- Hatched areas indicate space which is in excess to secondary sport requirements. In some cases, this can provide improved circulation and space for spectators and wheelchair users.
- The space cannot accommodate a full size 28.0 x 15.0 m basketball court and run off's. However, the rules can allow reduced court and run off sizes - see England Basketball rules.
- Community level badminton height of 6.7 m can accommodate volleyball at community level (see below) but with restricted headroom (below 7.0 m required) subject to agreement / conditions of use.
- The 17.4 m width accommodates two indoor cricket lanes with a clear central zone for potential basketball goals. (See ECB TS3 document pages 6 and 7 for criteria). However, lighting requirements for indoor cricket exceed those of badminton at community, club and premier levels of play, as indicated. Court space around the nets is also an important consideration. For instance, 2 lanes with adequate space around for additional safe practice / padding up can be preferable to 4 lanes with insufficient space for safe padding up and other practice.
- The minimum safety margins indicated between the cricket practice nets and walls should be increased if basketball training rings are fitted to the side walls - see the ECB TS3 document for further advice on recommended clearances.

Secondary Sports

Layouts for other sports within a five court badminton space of 39.50 x 17.40 x 6.70 / 7.50 / 9.00 m

Netball

- cannot be accommodated in a five court badminton space, unless it is made wider

Basketball

- see note above

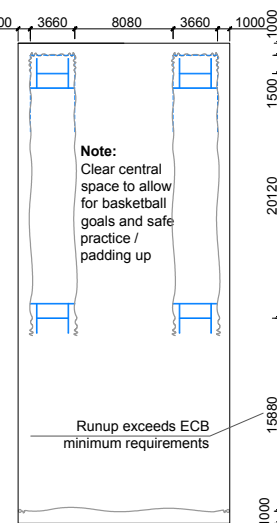

Volleyball (Community)

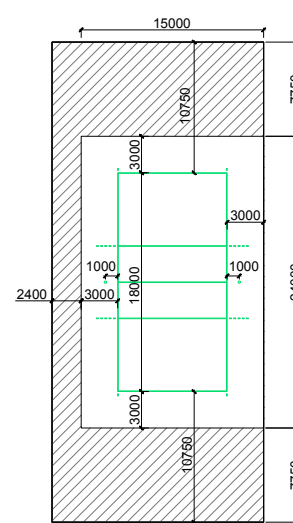

Volleyball (Premier)

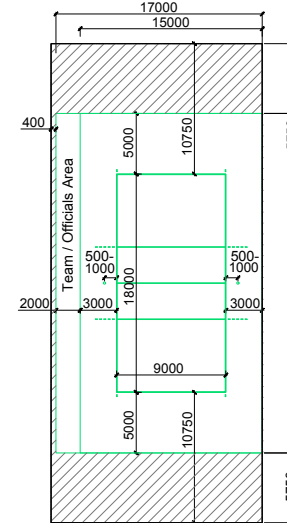

Volleyball Training (transverse)

- cannot be accommodated in a five court badminton space, unless it is made wider

Basketball Training

- can be accommodated in a five court badminton space
- number and location to project specific requirements

Primary Sport

Badminton - 5 Court (Int)				Source of information:		http://www.badmintonengland.co.uk http://www.sportengland.org/facilities_planning/design_and_cost_guidance.aspx											
International				Overall space (m) incl. R/O 42.50 x 17.40 x 9.00													
				Principal playing area (m)			Run offs (m)			Additional areas (m)		Specification					
							R/O			T/O	S/S						
				L x W x H	Length	Width	Height	Ends	Sides	Between courts / Between courts with a dividing net	Space for teams (T) and match officials (O)	Spectator seating	Flooring	Lighting			
				42.50	17.40	9.00	13.40	6.10	9.00	2.00	2.00	2.00/3.00	Essential	Essential	Combined elastics	1000 lux 0.7 Emin / eav	
Secondary Sports																	
Sport	Number	Compliance	Level														
Netball	0 court format	✗	-	34.50 18.25 7.50	30.50	15.25	7.50	2.00	1.50	3.00 / 3.00	-	-	Any meeting AENA standards	Lower (750 lux)			
Basketball	0 court format	✗	-	32.10 19.10 7.00	28.00	15.00	7.00	2.05	2.05	-	-	-	Semi-sprung wooden or synthetic	Lower (500 lux)			
Indoor Cricket	2 lanes	✓	Community / Club	33.62 12.72 7.70	31.62	3.66	7.70	1.00	1.00	3.40 for basket - ball goal	-	-	Mats req/d (to ECB standards)	Lower (750 lux)			
Volleyball	1 court format (lengthways)	✓	Premier	28.00 17.00 7.50	18.00	9.00	7.50	5.00	3.00	6.00 / 6.00	2.00	-	Area elastic	Lower (500 lux)			
Volleyball Training	0 court format (transverse)	✗	-	20.00 15.00 7.50	18.00	9.00	7.50	1.00	3.00	6.00 / 6.00	N/A	N/A	Area elastic	Lower (500 lux)			
Basketball Training	Rings on side walls	✓	Training	- - -													

Primary Sport / Secondary Sport Issues

Badminton - 5 Court International (cont/d)

Notes of key issues for a five court international badminton space

- See 'Key Issues' on page 1 cover sheet.
- Hatched areas indicate space which is excess to secondary sport requirements. In some cases, this can provide improved circulation and space for spectators and wheelchair users.
- For competition play, no allowance has been made for any officials beyond the end run off zones.
- The space cannot accommodate a full size 28.0 x 15.0 m basketball court and run off's. However the rules can allow reduced court and run off sizes - see England Basketball rules.
- The 17.4 m width accommodates two indoor cricket lanes with a clear central zone for potential basketball goals. (See ECB TS3 document pages 6 and 7 for criteria). Court space around the nets is also an important consideration. For instance, 2 lanes with adequate space around for additional safe practice / padding up can be preferable to 4 lanes with insufficient space for safe padding up and other practice.
- The minimum safety margins indicated between the cricket practice nets and walls should be increased if basketball training rings are fitted to the side walls - see the ECB TS3 document for further advice on recommended clearances.

Secondary Sports

Layouts for other sports within a five court international badminton space of 42.50 x 17.40 x 9.00 m

Netball

- cannot be accommodated in a five court international badminton space, unless it is made wider

Basketball

- see note above

Indoor Cricket

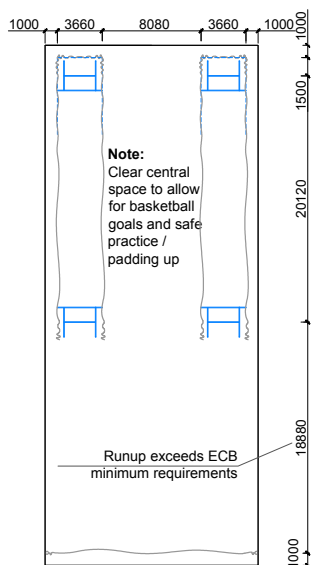

Volleyball (Premier)

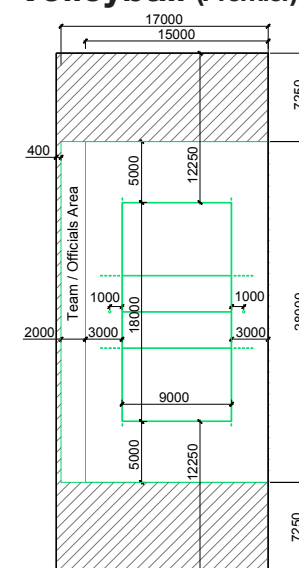

Volleyball Training (transverse)

- cannot be accommodated in a five court international badminton space, unless it is made wider

Basketball Training

- can be accommodated in a five court international badminton space - number and location to project specific requirements